

MO-FLEX BREEDING AND GESTATION BUILDING PLAN

Plan No. MO2-726-94C1

Developed by: Joseph M. Zulovich, Ph.D., P.E.
Commercial Agricultural Engineer
Animal Structures Specialist
University Extension - Commercial Agriculture Program
Agricultural Engineering Department
University of Missouri

© 1995 University of Missouri

WARRANTY DISCLAIMER:

The plan contained herein provides drawings and recommendations for the breeding and gestation building only. The drawings and recommendations are for a building based on 1994 Missouri structural requirements. NEITHER THE UNIVERSITY OF MISSOURI, UNIVERSITY EXTENSION NOR THE COOPERATIVE EXTENSION SERVICE, OR THEIR RESPECTIVE AGENTS OR EMPLOYEES, HAVE MADE, AND DO NOT HEREBY MAKE, ANY REPRESENTATION, WARRANTY OR COVENANT WITH RESPECT TO THE DRAWINGS OR RECOMMENDATIONS HEREIN. Additional professional services will be required to tailor this plan to your situation, including but not limited to:

- assurance of compliance with local codes and regulations;
- development and/or review of specifications for materials and equipment;
- selection of proper site providing adequate natural resource base;
- supervision of site preparation, bid letting and construction;
- development of a manure storage system and nutrient management plan;
- and provisions for utilities, roads and/or other access.

TABLE OF CONTENTS

	<u>Page</u>
WARRANTY DISCLAIMER	ii
Acknowledgments	v
The MO-Flex Breeding and Gestation Building	1
Manure Removal Impact	1
Ventilation Information	2
Structural Specifications for a MO-Flex Breeding and Gestation Building	3
Structural Lumber Specifications	3
Ceiling Construction	3
Truss Selection	4
Truss Erection	4
General Concrete Specification	5
Reinforcing Steel Requirements	5
Concrete Finishes	6
Concrete Slat Requirements	6
Insulation Requirements	6
Vapor Retarder Requirement	6
Interior Surfaces	6
Exterior End Walls	7
ADDITIONAL RESOURCES	8
APPENDICES	
A. Missouri Siphon Flush Tanks	10
B. Anaerobic Lagoon Systems	13
Submerged Inlet into Lagoon	14
Surface Inlet into Lagoon	15
Wet Well Installation for Lagoon Recycle Pump	16
C. Concrete Manure Storages	17

Acknowledgments

The author, Joe Zulovich, would like to acknowledge the help of other Commercial Agriculture Swine Team members during the development of this plan. John Hoehne, Commercial Agricultural Engineer (Animal Waste Specialist) and Charles Fulhage, Extension Agricultural Engineer, added input to the manure handling portions of the plan as well as reviewing several other portions of the plan during development. Rick Tubbs, Commercial Agriculture Swine Veterinarian, added input to the management and operational parameters of this plan. Rex Ricketts, Director of the Commercial Agriculture Program, provided a significant amount of additional funding which was used to obtain additional engineering drafting help to complete the drawing portions of the plan.

MO-FLEX BREEDING AND GESTATION BUILDING PLAN

The MO-Flex Swine Building System was developed to provide Missouri's independent swine producers with a comprehensive, standardized building plan package using current technology. The MO-Flex Breeding and Gestation Building is one production stage in the MO-Flex Swine Building System. Plan packages have been developed for each of the four stages of swine production; farrowing, nursery, grow-finish, and breeding-gestation. A plan package includes 20 - 17" x 22" sheets of construction drawings and a manual. The drawings show how a building should be built. This accompanying manual provides additional construction and specification details as well as a discussion of the design, operation and maintenance requirements of the building system.

The MO-Flex Breeding and Gestation Building

The number of head a breeding and gestation building holds will depend upon the sow group size and schedule of an operation. A breeding gestation building is sized for a specific operation and no general sizing procedure currently exists. The user essentially uses the included floor plans to develop an operation specific floor plan.

Manure Removal Impact

Manure should be removed from any swine building on a regular basis. When manure is removed from the building on a frequent basis, the ventilation system can be simplified because pit ventilation (air removal from manure/waste storage area) is not needed to help maintain indoor air quality.

Flushing under slats is the preferred manure removal system. No pit ventilation is required if flushing frequency for each gutter in a building is two hours or less. The flush system selected will have an impact on building length. Flush systems using flush tanks located inside the building require additional building length. A number of pen capacity combinations are not evenly divisible by four, so the additional space needed for flush tanks is usually not much of an issue. A siphon flush tank design (MO Siphon Tank) developed by Agricultural Engineering at the University of Missouri is included with this plan. This MO Siphon Tank is constructed as an integral part of the building, so it minimizes additional building length. Other available flush tanks having the same capacity as the MO Siphon Tank typically require more building space. This building plan allows for a minimum of 8' additional building length for other available flush tanks. One needs to determine the space requirement of the selected flush tank to insure that enough space is allowed for the tank during this initial building sizing phase. Another flush system design uses overhead pipe storage and therefore does not require additional building length for the system. This overhead storage flush system allows for the absolute minimum building length for the number of pigs housed.

Other manure removal systems available with this plan include pit recharge and gravity drain gutters

("Pull-plug" systems). The pit recharge system is a shallow pit that is filled with a minimum of 12" of recycled water from an anaerobic lagoon after the pit is drained on a regular basis. The gravity drain gutter system is a reversing hairpin gutter that drains the liquid manure either to an outside manure storage or an anaerobic lagoon. These two manure removal options should have mechanical pit ventilation systems. However, these two manure removal options generally do not impact on the length of the building.

Another consideration for manure removal impact includes the possible manure storage options available at the site a building will be constructed. Flush systems and pit recharge systems assume an anaerobic lagoon is available for manure storage. The gravity drain gutter system can be used in conjunction with an anaerobic lagoon or a liquid manure system. If an anaerobic lagoon cannot be built near the building site, the gravity drain gutter system is the manure option for the building.

Ventilation Information

Most breeding and gestation buildings use tunnel ventilation for hot weather ventilation. One end of the building will have the exhaust fans and the other end will have a cool cell inlet system. Winter and mild weather inlets are placed in the ceiling to provide reasonable air distribution in winter. Summer tunnel ventilation rates should be at least 80,000 to 100,000 cfm for a 40' wide building. The winter ventilation rate should be at least 10 cfm per animal in facility. Fan system with controller should be staged to provide the winter rate in cold weather and increase to max tunnel rate in hot weather. Consult cool cell manufacturer/supplier for cool cell sizing and installation details. Supplemental heater capacity can be estimated as 1,000 BTU/hr heater capacity per animal housed in facility.

Structural Considerations for a MO-Flex Breeding and Gestation Building

Design loads used for the building structure follow Standard ANSI/ASCE 7-93, Minimum Design Loads for Buildings and Other Structures. The live load for the roof structure was 20 psf (pounds per square foot). Wind loads for the structure were based on an 80 mph wind speed. Appropriate dead loads were included. Structural design details given in this plan meet required load conditions for Missouri. NOTE: If changes are made to structural design of the building, the changes shall be certified by an engineer to insure the proposed changes will provide adequate strength to meet required loads at the location the building is constructed.

The structural design details included in this plan should not be used in areas where either the design roof live load (ie. snow load) or the design wind speed is exceeded. Areas where either the roof live load or the wind speed are exceeded require different structural design details than ones included in this plan. An engineer will be required to redesign and certify the necessary structural changes so that the new design will meet the load conditions of the new area.

Structural Lumber Specifications

Lumber quality of all structural components is to be Number 2 Southern Pine or better. Treated lumber is to be 0.6 PCF CCA treated. Structural components include 2x6 post members, bottom plate, 2x8 bottom girt, 2x10 top girt, and purlins, either 2x4 or 2x6. Structural members for this MO-Flex Breeding and Gestation Building exposed to moisture include 2x6 post members, bottom plate, 2x8 bottom girt, and 2x10 top girt and need to be CCA treated members. If a lesser quality of lumber is used, the structural design detail may be inadequate and may require an engineer to redesign the structure for poorer quality lumber.

Ceiling Construction

Construction of the insulated ceiling may be accomplished by several different techniques. Owners and builders should determine with what and how a ceiling is actually constructed. The finished ceiling construction should have an R-value of 30 and have the proper interior surface characteristics. Two acceptable methods are given below.

One method of ceiling construction is to attach 29 ga. corrugated aluminum directly to the bottom chord of the trusses after a vapor barrier is installed. If a metal ceiling construction is used, the truss manufacturer should be notified when purchasing trusses because the ceiling may provide the necessary bottom chord bracing.

Another method of constructing the ceiling is to use a flexible plastic sheet material for the ceiling. The flexible plastic sheet can provide the desired surface characteristics and hold insulation adequately but will not provide bottom chord bracing. Additional framing may be required to provide the necessary bottom chord bracing.

If no ceiling is constructed, bottom chord bracing will probably be required.

Truss Selection

Trusses for the MO-Flex Swine Buildings have the following specifications:

Roof Slope:	4/12
Loading Criteria:	For insulated ceiling (20#-4#-0#-5#) Top chord live load - 20 psf Top chord dead load - 4 psf Bottom chord live load - 0 psf Bottom chord dead load - 5 psf For insulated roof line and no ceiling (20#-7#-0#-1#) Top chord live load - 20 psf Top chord dead load - 7 psf Bottom chord live load - 0 psf Bottom chord dead load - 1 psf
Support Width:	41' (Exterior posts are 41'-6" apart [exterior face to exterior face])
Top Chord Overhang:	18" to help protect curtain sidewalls
Truss Spacing:	4' o.c.
Purlins:	For insulated ceiling, 2x4's at 24" o.c. attached flat on top For insulated roof, 2x6's at 39" o.c. attached on edge
Bottom Chord Bracing	Follow BWT-76 from Truss Plate Institute. Indicate construction method of ceiling (if used).

Trusses should be purchased from a truss supplier. Truss design should be certified by an engineer to meet the required loading.

Truss Erection

Truss erection and temporary bracing are important considerations during the design process of a truss. However, this component is the most difficult to manage from the building designer's point of view because of differences between construction crews and locations. Even though erection is the most difficult to manage, truss engineering firms are greatly concerned because of the potential loss of human life and property losses due to a construction accident during truss erection. Information on proper truss erection is available from "Bracing Wood Trusses" (BWT-76) and Handling and Erecting Wood Trusses (HET-80). Both pieces are available from the Truss Plate Institute. "Commentary and Recommendations for Handling, Installing and Bracing Metal Plate Connected Wood Trusses" (HIB-91) is another document from the Truss Plate Institute and provides diagrams and specifications for getting trusses safely installed.

General Concrete Specification

Concrete is used in the MO-Flex Breeding and Gestation Buildings for footings, exterior stub walls, flooring for manure handling systems, interior stub walls and/or concrete siphon flush tanks. Concrete specifications are as follows:

- Minimum 3,500 psi compressive strength (about a 6 bag mix),
- Air-entrained,
- Maximum aggregate size of 1 inch,
- Maximum slump of 4 inches.

This level of concrete quality is required to obtain the desired finishing and durability characteristics.

Reinforcing Steel Requirements

Reinforcing steel should be included in all structural concrete for MO-Flex Breeding and Gestation Swine Buildings. Structural concrete includes slab on grade construction, footings, exterior structural walls and/or concrete siphon flush tanks. Reinforcing steel is required not only for structural strength but also for temperature and shrinkage reinforcement.

Footings: Footings require two #4 bars running the entire length and located about 8" apart in the lower third of the footing. When footings go around corners, each corner should have #4 dowels to maintain the steel around each corner.

Slabs on Grade: Concrete floors 4" thick require #4 bars at 18" o.c. in both directions and located at the vertical center of the slab.

Exterior Structural Walls: Steel requirements for 8" exterior concrete walls include both vertical and horizontal steel reinforcing. Vertical steel should be #4 bars, 16" on center throughout the length of the exterior walls. Horizontal steel should be #4 bars, 10" on center (maximum) throughout the height of the exterior walls. For 4' high exterior walls, five (5) rows of #4 bars should be used (See sheet F4). For 5' high exterior walls, seven (7) rows of #4 bars should be used (See sheets P3 and/or H3).

Concrete Siphon Flush Tanks: If MO Siphon Flush Tanks are to be built, reinforcing steel requirements are detailed in drawings on sheets F7 and F9. Steel requirements for the siphon flush tank provide structural strength. If the steel requirements are not followed, a tank failure is possible.

Above steel reinforcing requirements are given as general recommendations. Drawings that accompany this plan should be examined to find locational details for reinforcing steel requirements of any particular concrete structural components.

Concrete Finishes

Structural Walls and Siphon Tank: All vertical structural walls, including concrete siphon tank components, should be vibrated during placement of the concrete. Vibrating is required to minimize honeycombing; insure that concrete entirely fills forms and also adheres to all connection and steel reinforcing.

Slabs on Grade: Concrete slabs on grade should be finished to a smooth float finish. The finish should be smooth enough so that manure removal is not inhibited. Also, the finish should be such that no aggregate or holes are left at the top surface to allow manure to easily begin corrosion of the concrete surface.

Alleys or Walkways: Alleys or walkways where human or animal traffic exist should have a non-skid surface. Concrete surfaces for alleys or walkways should first have a smooth float finish and then be completed with light to medium broom finish. The float finish is first required to give a durable surface, and the broom finish is to provide a non-skid surface for traffic.

Concrete Slat Requirements

Concrete slats for the MO-Flex Breeding and Gestation Building are standard, commercially available breeding and gestation gang slats. Slot width should be 1½ inch. Actual slat width and surface characteristics are left for the building owner to select. All manure handling options use 8' gang slats.

Insulation Requirements

Insulation levels are shown on the drawings. Insulated components include: building perimeter, exposed concrete walls, frame end walls, and ceiling or roof. Reduced insulation levels from those shown on the drawings will increase heat loss from the building shell and result in higher heating costs.

Vapor Retarder Requirement

A vapor retarder should be placed behind the inside surface material of all insulated building components. An acceptable vapor retarder is 6-mil plastic. The plastic should be continuous and should be either sealed or overlapped at least 6" at joints. Other materials which meet vapor retarder performance of 6 mil plastic may be substituted.

Interior Surfaces

Interior surfaces can be constructed from a variety of materials. Interior surfaces should be non-porous. Surfaces need to withstand repeated high pressure washings using detergents and disinfectants. Typical surfaces include corrugated galvanized metal, corrugated aluminum and glassboard.

Exterior End Walls

Exterior end walls should be constructed as 2x6 stud frame walls using standard framing techniques. The sill plate should be CCA treated and attached to the concrete wall with ½" x 8" anchor bolts at a maximum of 36" on center. Insulation should be placed between the 2x6 studs to provide an R-value of about 19. A vapor retarder should be placed on the inside of the wall just under the interior wall surface. Exterior siding is placed on the outside of the walls.

ADDITIONAL RESOURCES

- ACI. 1989. Building Code Requirements for Reinforced Concrete and Commentary (ACI 318-89). American Concrete Institute. Detroit, MI.
- Ahrens, D. L. 1976. Concrete and Concrete Masonry. Hobar Publications. Division of Hobar Enterprises, INC. St. Paul, MN.
- AISC. 1989. Manual of Steel Construction, Allowable Stress Design, 9th Edition. American Institute of Steel Construction, Inc. Chicago, IL.
- Albright, L. D. 1990. Environment Control for Animals and Plants. ASAE Textbook No. 4. American Society of Agricultural Engineers. St. Joseph, MI.
- ASAE. 1990. STANDARDS 1990, Standards, Engineering Practices and Data, 37th Edition. American Society of Agricultural Engineers. St. Joseph, MI.
- ASCE. 1993. Minimum Design Loads for Buildings and Other Structures, ASCE 7-93. American Society of Civil Engineers. New York, NY.
- Driggers, L. B. 1990. Ventilation of Swine Buildings Using the North Carolina Underslat Ventilation System. The North Carolina State Agricultural Extension Service. North Carolina State University. Raleigh, NC.
- Gustafson, R. J. 1988. Fundamentals of Electricity for Agriculture, 2nd Edition. American Society of Agricultural Engineers. St. Joseph, MI.
- Hellickson, M. A. and J. N. Walker. 1983. Ventilation of Agricultural Structures. ASAE Monograph 6. American Society of Agricultural Engineers. St. Joseph, MI.
- Hiatt, R. S. 1993. Agricultural Wiring Handbook (Tenth Edition). National Food and Energy Council. Columbia, MO.
- Midwest Plan Service. 1983. Swine Housing and Equipment Handbook (MWPS-8). Midwest Plan Service. Ames, IA.
- Midwest Plan Service. 1983. Revised 1987. Structures and Environment Handbook (MWPS-1). Midwest Plan Service. Ames, IA.
- Midwest Plan Service. 1989. Farm and Home Concrete Handbook (MWPS-35). Midwest Plan Service. Ames, IA.
- Midwest Plan Service. 1989. Natural Ventilating Systems of Livestock Housing (MWPS-33). Midwest Plan Service. Ames, IA.
- Midwest Plan Service. 1990. Mechanical Ventilating Systems of Livestock Housing (MWPS-32). Midwest Plan Service. Ames, IA.

- Midwest Plan Service. 1990. Heating, Cooling and Tempering Air for Livestock Housing (MWPS-34). Midwest Plan Service. Ames, IA.
- Midwest Plan Service. 1992. Farm Buildings Wiring Handbook (MWPS-28). Midwest Plan Service. Ames, IA.
- Midwest Plan Service. 1994. Concrete Manure Storages Handbook (MWPS-36). Midwest Plan Service. Ames, IA.
- NDS. 1993a. NDS "National Design Specification for Wood Construction, Revised 1991 Edition." American Forest and Paper Association. Washington, DC.
- NDS. 1993b. NDS Commentary "Commentary on the National Design Specification for Wood Construction, Commentary on the 1991 Edition." American Forest and Paper Association. Washington, DC.
- NDS. 1993c. NDS Supplement "Design Values for Wood Construction, Revised Supplement to the Revised 1991 Edition." American Forest and Paper Association. Washington, DC.
- Parker, H. 1975. Simplified Engineering for Architects and Builders, 5th Edition. John Wiley & Sons, Inc. New York.
- Pork Industry Handbook. Purdue University Cooperative Extension Service. West Lafayette, IN.
- Truss Plate Institute (TPI). 1976. Bracing Wood Trusses: Commentary and Recommendations. BWT-76. Madison, WI.
- Truss Plate Institute (TPI). 1980. Handling and Erecting Wood Trusses: Commentary and Recommendations. HET-80. Madison, WI.
- Truss Plate Institute (TPI). 1991. Commentary and Recommendations ofr Handling, Installing and Bracing Metal Plate Connected Wood Trusses. HIB-91. Madison, WI.
- Walker, J. N. and F. E. Woeste. 1992. Post-Frame Building Design. ASAE Monograph 11. American Society of Agricultural Engineers. St. Joseph, MI.
- Wang, C. K. and C. G. Salmon. 1985. Reinforced Concrete Design, 4th Edition. Harper and Row, Publishers. New York.

A. Missouri Siphon Flush Tanks

Flushing is the preferred means of removing manure from MO-Flex Swine Buildings, and siphon flush tanks have attained preference as a water release device due to their simplicity and durability. A few commercially built siphons are available, and if properly sized and installed, work quite well. In Missouri, we have had considerable success with a "home-made" siphon design. Drawings are included in this plan to build MO Siphon Tanks as an integral part of the building structure. However, other water release devices can be used with MO-Flex Swine Buildings.

MO Siphon Tank Components

Although detailed knowledge of siphon operation is not necessary for construction of a siphon, a basic understanding of how a siphon works can help in judging its application and feasibility for a particular individual. The "Missouri" siphon tank consists of the following basic components as noted below and shown in figure 1.

1. Tank
2. Bell with Vent Hole
3. Discharge Pipe
4. Trigger Tube
5. Trap

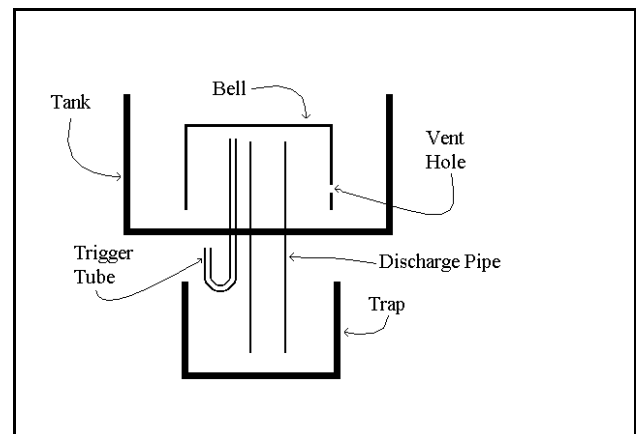

Figure 1. Siphon Tank Components

Siphon Tank Operation

The operational sequence of the Missouri Siphon Flush Tank is described in the following section. The simplicity of this siphon tank is realized by understanding the operation. No moving parts exist with the operation of the tank.

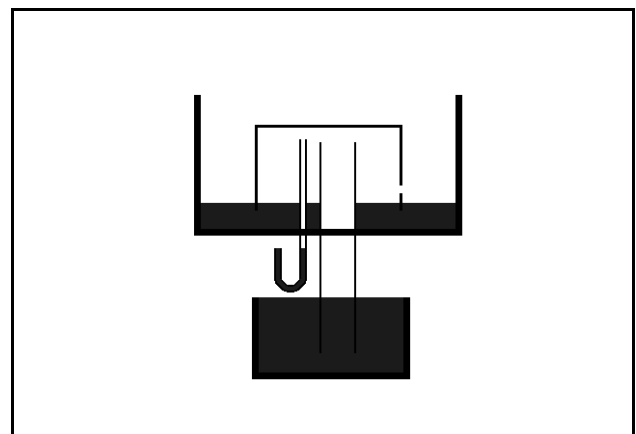

Figure 2. Beginning of Fill

The sequence of operation of the siphon tank begins with the tank filling with water as shown in figure 2. At the beginning of fill, subsequent to a prior flush, water occupies the shaded portions of the system. As the tank continues to fill, water covers the vent hole in the bell and a specific volume of air is trapped under the bell and in the discharge pipe. After the vent hole is covered, the water level under the bell rises at a slower rate than the water level in the tank. Also, the water levels in the discharge pipe and trigger tube are "pushed downward" by air pressure as water rises inside the bell.

Figure 3 shows the water levels in the various components of the siphon tank during the filling process. The water level in the tank will continue to rise faster than the water level under the bell. Also, the water levels will continue to drop in the trigger tube and discharge pipe until the tank is full.

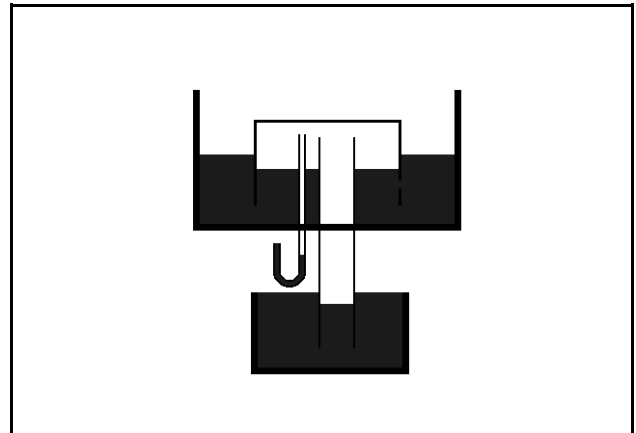

Figure 3. During the Fill

At the end of the fill cycle, water levels are as shown in the figure 4. At the end of fill, air is "pushed" around the bottom of the "U" in the trigger tube. This blows the remaining water out of the "up" leg of the trigger tube and allows the air to escape from under the bell. When air is purged from the system, water fills the area under the bell and the discharge pipe, and flow begins.

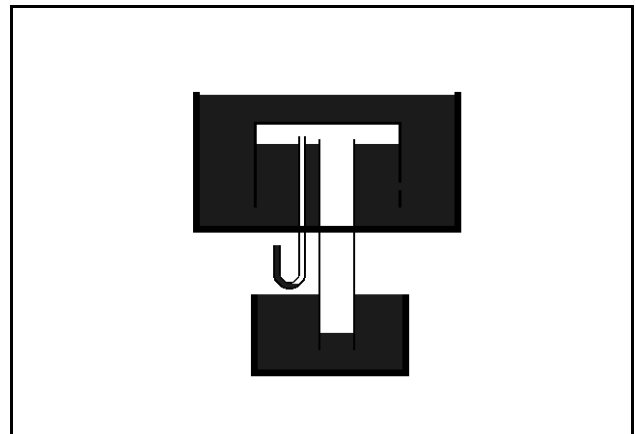

Figure 4. End of Fill

At the beginning and during flow water occupies the area under the bell as shown in figure 5.

After flow is established, the water level in the tank continues to drop until air enters the system underneath the bottom edge of the bell, and the siphon "breaks." Since the vent hole is exposed at this point, air is admitted into the bell until atmospheric pressure exists and conditions are correct for the next fill cycle as shown in figure 1. If properly installed, the trigger tube will refill with water during the tank discharge cycle as shown in figure 5.

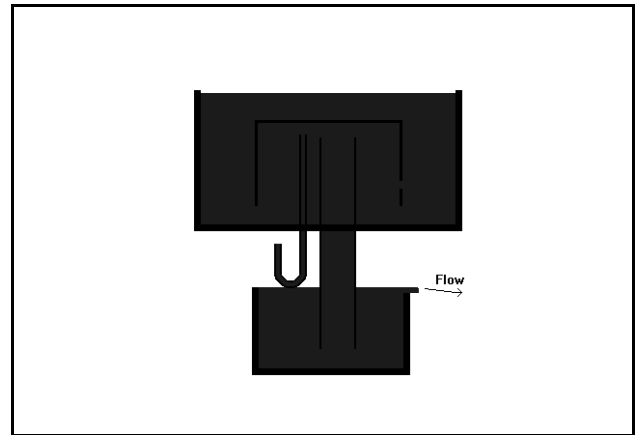

Figure 5. Beginning of Flow

By examining figures 1 through 5, one can ascertain that rather precise dimensions and construction/installation techniques are necessary in order to insure that the Missouri Siphon Flush Tank operates properly. Some of the parameters which are critical to siphon design and operations include:

1. Tank area in plan view and tank depth
2. Bell area in plan view and number of bells
3. Discharge pipe diameter and number of pipes
4. Trigger tube diameter
5. Depth of tank
6. Vent hole diameter and placement
7. Distance discharge pipe extends into tank
8. Distance discharge pipe extends into bell
9. Height of bell above bottom of tank
10. Length of "open" leg of trigger tube.

Siphon flush tanks **MUST** be built strictly according to plans to insure proper operation.

Siphon Tank Start-up Procedure

This start-up procedure insures that the tank will flush at the desired level by accounting for construction tolerances.

1. Make the "up" leg of the trigger tube 2" longer than indicated on the plan.
2. Fill trigger tube and sump. Then fill tank with fresh water to desired level and shut off water.
3. Drill ¼" holes in ¼" increments down from the top edge of the "up" leg of the trigger tube until tank flushes. For safety, use a cordless drill due to the wet environment.
4. Cutoff trigger tube pipe at last hole drilled when tank flushed.
5. Use fresh water during the start-up procedure.

B. Anaerobic Lagoon Systems

Anaerobic lagoon systems are a popular manure storage and treatment option for Missouri. Anaerobic lagoons are earthen structures that must be designed and built to meet Missouri Department of Natural Resources regulations. An anaerobic lagoon system is needed for use with flush and pit recharge manure handling and removal systems. A hairpin gutter manure system can also be used with an anaerobic lagoon.

PVC pipe is recommended to connect manure handling systems from building(s) to the anaerobic lagoon. A submerged inlet, shown in Figure 6, allows effluent to flow into an anaerobic lagoon without the potential of cold air entering a building through the drain line. A submerged inlet can help reduce odor potential from manure effluent draining from a building. A surface inlet, shown in Figure 7, can be used instead of a submerged inlet.

A recycle pump system will be required for both a flush and a pit recharge manure system. The recycle pump used for a recycle system should be a submersible, sewage ejector type of pump. A sewage ejector pump has larger impeller tolerances which allow the pump to operate longer between services. A wet well, shown in Figure 8, is located in the anaerobic lagoon bank to supply the recycle water. A wet well installation allows for easier maintenance of the recycle pump. To service the pump, one can simply lift the pump from the wet well instead of having to either drag the pump out of the lagoon or raft out onto the lagoon.

The build-up of salt crystals (struvite) is a common problem when using recycle systems. An acid cleaning system should be considered to help maintain any recycle system. Muriatic acid solution (a 10% hydrochloric acid) can be circulated through a recycle system to dissolve the struvite. If a wet well is used, the acid cleaning system can be relatively easily incorporated into the recycle system. An acid cleaning system generally consists of an acid storage tank and a small acid recycle pump. The acid recycle pump can be plumbed into the union of the recycle pipe that connects to the building(s), and a return line can be laid on the ground to return the acid back to the storage tank. The circulating acid will dissolve any salt build-up in the recycle line(s). If an acid recycle system is desired, the small stud frame building could store the acid recycle system.

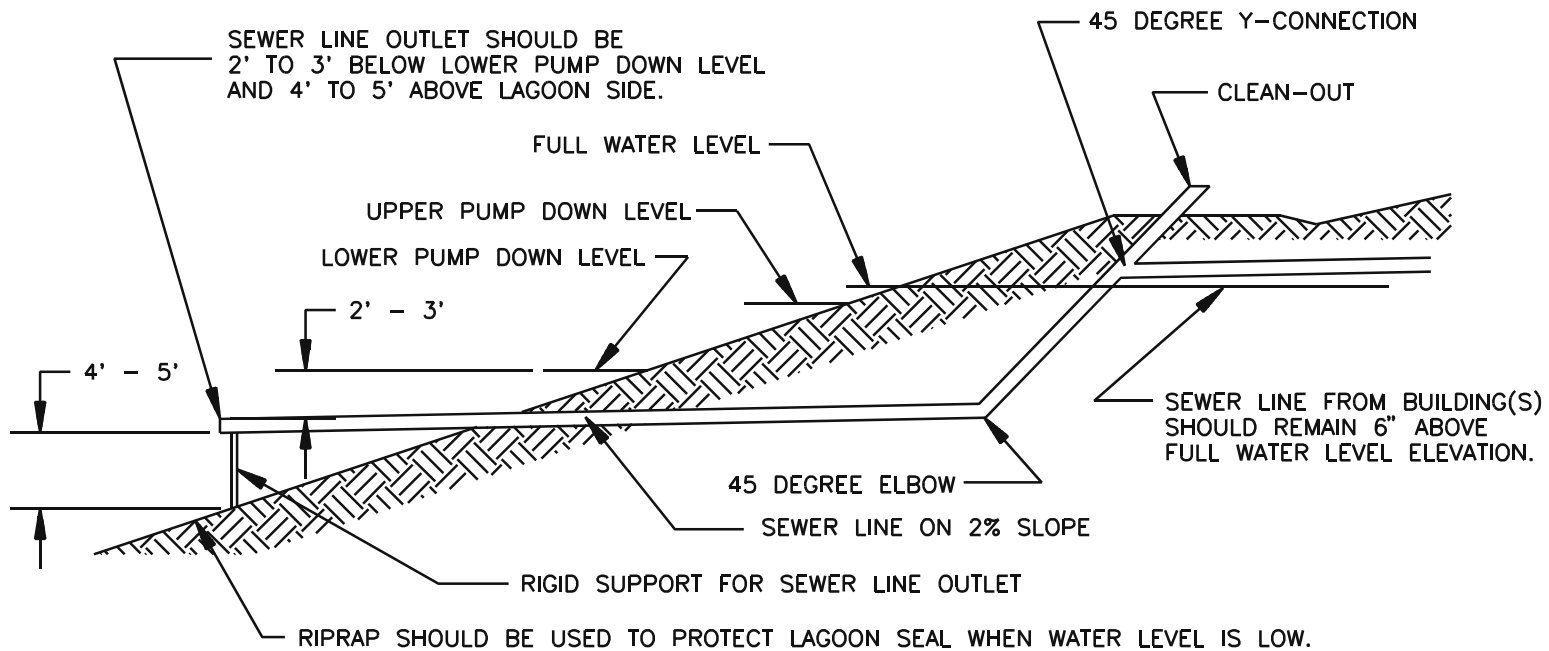

Figure 6. Scaled Sketch of Submerged Inlet into Anaerobic Lagoon.

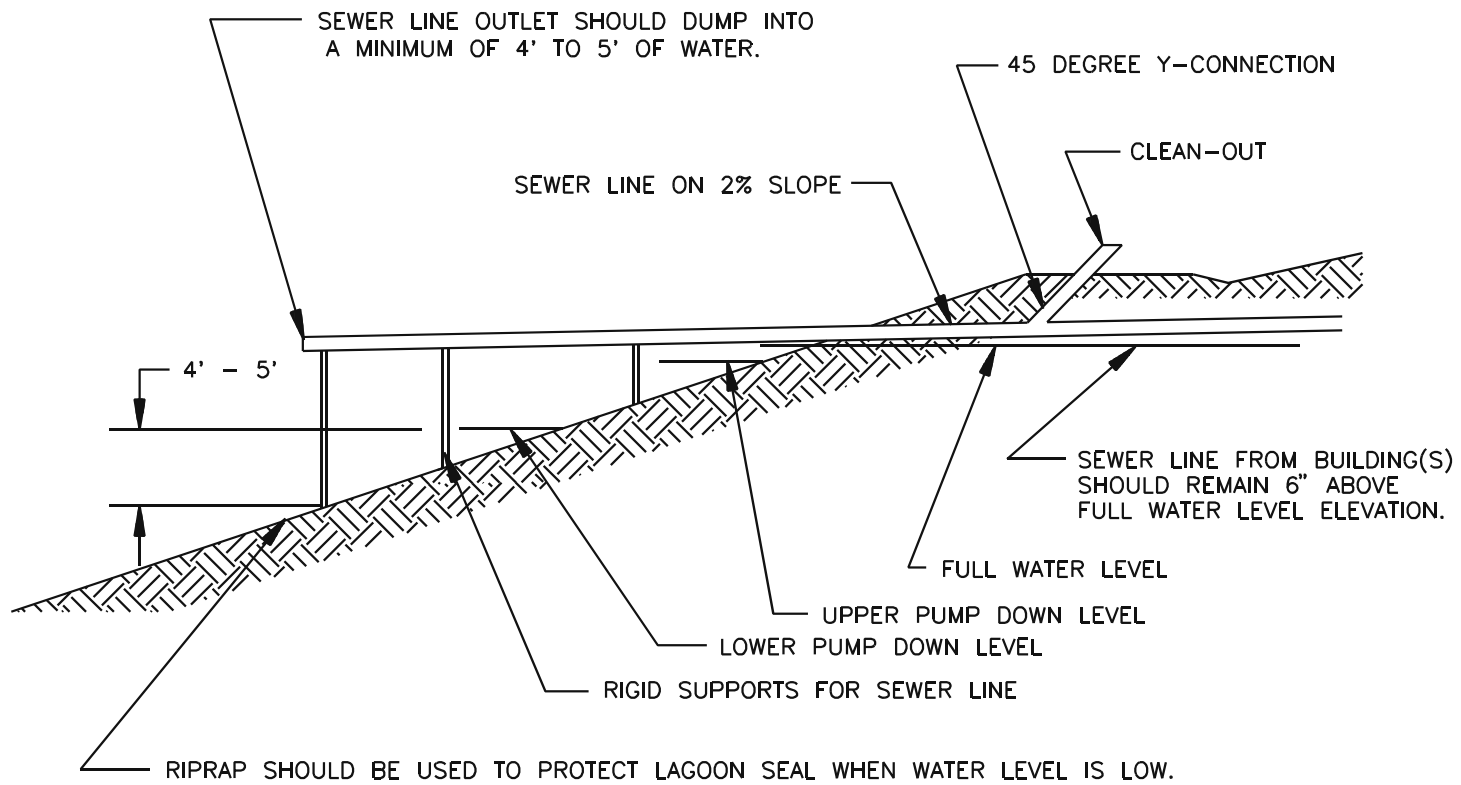

Figure 7. Scaled Sketch of Surface Inlet into Anaerobic Lagoon.

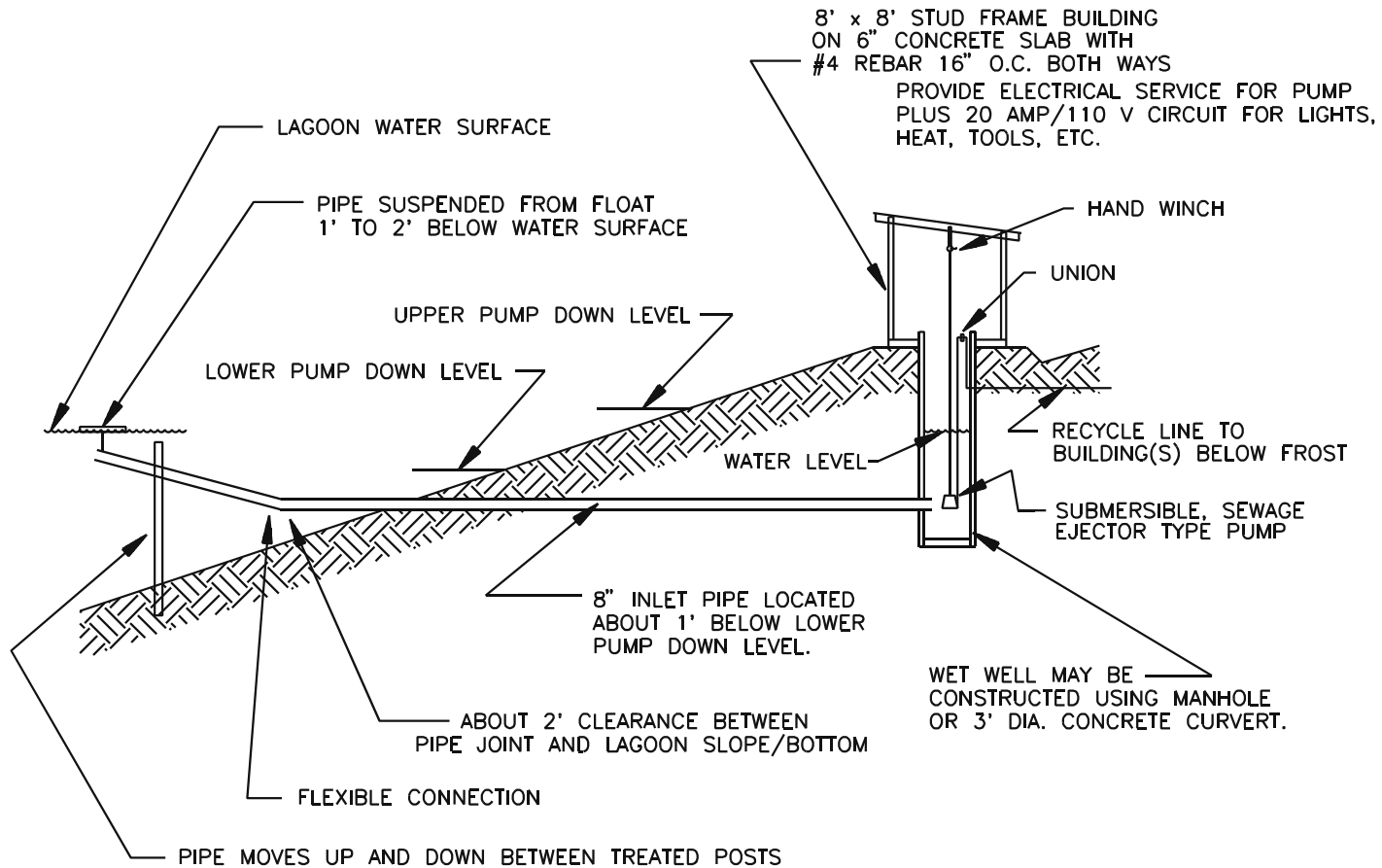

Figure 8. Scaled Sketch of Wet Well Installation for Lagoon Recycle Pump.

C. Concrete Manure Storages

The gravity drain gutter system allows for a liquid manure system. If the gravity drain gutter option is selected, an outside manure storage structure will be needed. Several types of structures are possible to serve as a liquid manure storage facility. Concrete manure storage facilities are probably the most common type of swine manure storage structure.

This MO-Flex Breeding and Gestation Building Plan does not have a manure storage plan included with the building plan. Information for designing and constructing concrete manure storages is available Concrete Manure Storages Handbook (MWPS-36). This handbook provides design criteria, reinforcing selection and construction details for liquid manure storages. However, local requirements and conditions may require specific design changes. A liquid manure storage should be certified by an engineer to insure that the structure will meet the required loads and comply with an environmental regulations.