



PURDUE UNIVERSITY COOPERATIVE EXTENSION SERVICE • WEST LAFAYETTE, INDIANA

Swine Farrowing Units (Keywords: Farrowing, Farrowing Buildings, Housing)

Authors:

Charles M. Stanislaw, North Carolina State University
Arthur J. Muehling, University of Illinois

Reviewers:

Scott Carter, North Dakota State University
John Thomson, South Dakota State University
Jerry Thurman, Cedar Vale, Kansas

A wide variety of choices is available in farrowing units from the A-frame portable building on pasture to the environmentally-controlled central farrowing unit with slotted floors. Although good management and proper environment are the most important requirements for a successful farrowing operation, well-planned and properly constructed buildings and equipment make both easier.

When selecting a farrowing unit, consider the amount and availability of capital, labor, buildings, and management, and the future size of the operation. While the sow and pigs need a certain environment for optimal performance, this environment can be provided in many ways and should be accomplished in the ways best suited to each producer's conditions. Perhaps a higher level of management is required with a central farrowing house than with a pasture operation. However, with central farrowing the labor required is reduced, and one person can handle more sows. A production schedule should be developed to assure that the farrowing unit is utilized to capacity.

Critical Design Factors

Comfort

The farrowing unit must provide physical comfort for the young nursing pigs and for the sow. Each has different environmental requirements. Ideally, the newborn pig needs a clean, dry, draft-free environment with clean air and a temperature of about 85°F to 90°F the first three days of life. In contrast, the most comfortable temperature for the sow is approximately 60°F to 65°F.

In central farrowing units, these two temperature requirements are handled by maintaining a room temperature of about 65°F to 75°F and providing supplemental

zone heat for the young pigs. Solid floor units using bedding can be maintained at a lower room temperature than slotted floor houses. In a house that is open or not environmentally controlled, provisions such as draft barriers, bedding, and hovers are needed.

Comfort considerations also can be judged by observing the activity of the pig. Peak efficiency is most easily obtained from a building in which it is comfortable and pleasant for a person to work and in which the pigs appear comfortable.

Protection

Farrowing crates reduce the number of pigs crushed by the sow. In open-pen farrowing, guardrails located about 6 in. out from the wall and 8 in. up from the floor will reduce the number of pigs crushed. A separate comfort zone for the baby pigs provides additional protection by attracting them away from the sow except when nursing.

Crates have been designed with a variety of features to protect the small pigs from being overlaid and to improve accessibility to the sow's udder for nursing. A common modification of the standard crate is movable bars that restrict the sow as she prepares to lay down, but which move away when she stands up. Another modification is the shape of the bottom bar of the crate which typically is either bowed out to provide greater piglet access to the udder or is mounted several inches higher from the floor with vertical "fingers" (Figure 1).

Sanitation

Farrowing units should be easy to keep clean. Porous or rough surfaces should be avoided as they can harbor bacteria. Rough floor surfaces not only are abrasive to the feet and knees of nursing pigs but they also retain

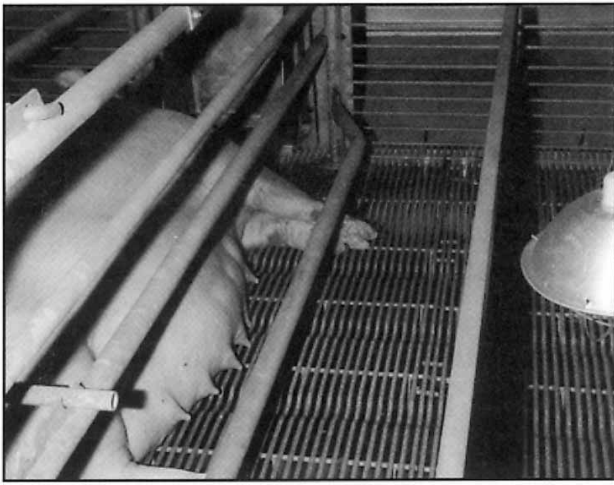

Figure 1. Farrowing crate with bottom bar bowed out to facilitate piglet nursing.

moisture and manure. Smooth floor surfaces drain better, dry more rapidly, and are easier to clean and disinfect, but can be slick.

Solid floors should be sloped for proper drainage--about 1/2 in. per foot. Slotted floor surfaces should be flat and smooth. Flooring made of materials that could be slick (aluminum, stainless steel, plastic) should have a nonabrasive, textured surface to provide traction for the sows and pigs.

Management

Proper management in central farrowing units is much easier if farrowings are grouped. Establish a schedule for breeding so that each group has all the pigs farrowed within one week. This makes it possible for an all-in, all-out system where the room is completely emptied, cleaned, and disinfected between groups of sows.

At all times, the attendant must be able to recognize signs of environmental stress in the animals and to make appropriate adjustments. Piled up or shivering pigs are cold regardless of the ambient temperature. Also, drafts and dampness affect the comfort zone, and more heat is required to overcome the uncomfortable environment. Likewise, pigs lying everywhere but under or on the heat source indicate the supplemental heat supply is too warm. Operators also must be alert when any disease or other disorder occurs. They must detect what is wrong immediately and administer appropriate treatment. The good manager learns to detect minor or developing problems and thereby prevents them from becoming major.

General Decisions

Permanent or Portable Buildings

Portable buildings should be considered by individuals who either are renting land or choose not to make a major commitment to swine production. Some landowners may have no interest in providing permanent structures; hence, portable buildings become the only alternative. They usually require more total land area and total labor per animal unit. Also, proper management can be complicated by inclement weather. Today there are

farrowing units that approach permanent buildings but are still portable. Smaller units are constructed as a complete unit, and larger units are composed of individual sections in a communal arrangement but are moved separately.

Permanent central farrowing units are designed to support year-round farrowing and must keep the pigs warm in the winter and the sows cool in the summer. This involves a large financial investment. The only means of recovering this investment is by using them continuously for their intended purpose, farrowing. The complex nature of modern central farrowing facilities with pits and slotted floors permits no alternative use. Multiple or continuous farrowing that produces at least six or more litters per stall per year is required to justify the more specialized central farrowing house. A producer who invests in modern, permanent farrowing facilities makes a definite commitment to hog production.

Site Location

Proper site location involves several basic considerations. The soil must be well drained. If it is necessary to do land leveling for a foundation site, the soil must be well compacted before construction begins. Settling under a part of the foundation could cause the building to crack.

The farrowing facilities should be part of a total arrangement of facilities: nursery, growing-finishing, gestation, feed processing, and manure disposal. An organized arrangement of physical facilities provides the most efficient means of moving animals, feed, and manure. This involves connecting lanes for moving animals from building to building and augers or similar devices for mechanically moving feed from the processing center to bulk tanks at each building. A long-range plan needs to be developed that will include the possibility of multiple site production.

While it is desirable to have the farrowing unit convenient to the farm home, the swine buildings must not create undesirable living conditions for the home occupants. Odors are generally more pronounced in warm, humid weather. Therefore, place the buildings so prevailing summer breezes do not carry odors to the home. Be sure to check local and state environmental ordinances with respect to location next to property lines or neighboring residences. For more detailed information, see [PIH-117, "Planning Considerations for the Construction of a New Swine Unit"](#).

Crates or Pens

When choosing between farrowing crates and farrowing pens, the primary differences are the amount of exercise the sow receives and the amount of protection afforded the pigs. With crates, the sow is essentially completely restrained and the pigs are protected from overlying. If pens are used, they generally work better for producers who wean at 4 to 5 weeks of age while those who wean younger generally have crates. There are several arrangements in use where the sow may be restrained the first few days, but later the sides of the crate swing open allowing the sow to turn around. Some tethering has been used but is less common.

Most crate dimensions are 5 ft. wide by 7 ft. long, but can vary from 4 1/2 ft. to 5 ft. wide and from 6 to 7 ft. long. They are usually adjustable to accommodate very large or very small sows. The width includes an 18-in. creep

area on both sides of a 24-in. sow stall. Research on farrowing crate design has shown varied results. Which crate is best depends on the criteria used to evaluate the performance. Roomier crates favor the sow's comfort and well-being, but the newborn pigs are better in the smaller crate. Grates with fingers or crates with bowed out bottom bars facilitate nursing.

Solid or Slotted Floors

Slotted floors greatly reduce the labor required to remove manure. Also, by providing drainage for urine and spilled drinking water, they maintain drier floor surfaces than is possible with solid floors. Pigs stay clean with little work.

Slotted floors are available in a number of different materials and designs. Over the years some have been made on the farm of concrete and wood, but the majority have been commercially manufactured from many materials including steel, plastic, fiberglass, cast iron, aluminum and concrete.

Bare woven wire is used by many producers (Figure 2). The early woven wire was 5 gauge but today 00 gauge is most common. Some of the heavier wire is being flattened on the top side to make it more comfortable for pigs to walk on. An adequate support system must be provided to minimize the deflection. Inadequate support results in shorter life and unsatisfactory performance of the flooring material.

Metal flooring made from a triangular solid steel bar is supplied in various sized sections. The flooring section has a prestressed bridging system which supports the loading. All flooring sections are hot-dipped in zinc. Some designs have a heated section available for the small pigs and a cooled section under the sow. The sections under the sow may be bent to help prevent slippage (Figure 3).

Plastic coated metal flooring (Figure 4) is warmer than bare metal and more comfortable for the pigs. Some coated flooring has had the coating broken under the sow's sharp front feet but improved-coatings have reduced this problem. The solids behind the sow often do not work through some of the coated metal flooring as well as through bare metal.

Plastic slotted flooring of various types and shapes has been available for many years. The plastic floors are warmer than concrete or metal and they clean up readily. A number of the plastic floorings have been slippery for the sows but more recent designs have largely corrected this. A plastic flooring that has been getting extensive use with very favorable comments from pork producers is a system using modular, interlocking grate sections (Polygrate) supported with flat steel, concrete or fiberglass beams. It appears to have good traction for the sow, is warmer than steel, cleans adequately, and is easy to install (Figure 5).

There are very few wood or concrete slats being used for farrowing today. Some crates have a combination of materials such as concrete slats under the sow and coated wire on the sides in the pig areas. When applicable, run slats parallel with the sow. This provides better footing for the sow when she gets up and for the pigs when nursing. For more details on different types of flooring, see PIH-53, "Flooring for Swine".

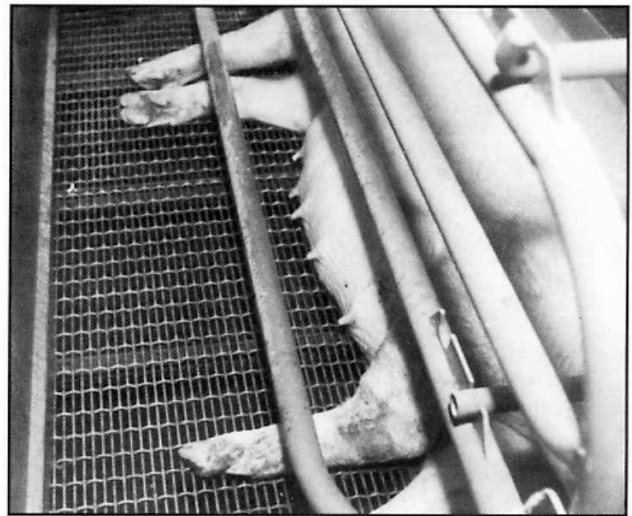

Figure 2. Farrowing crate with woven wireflooring.

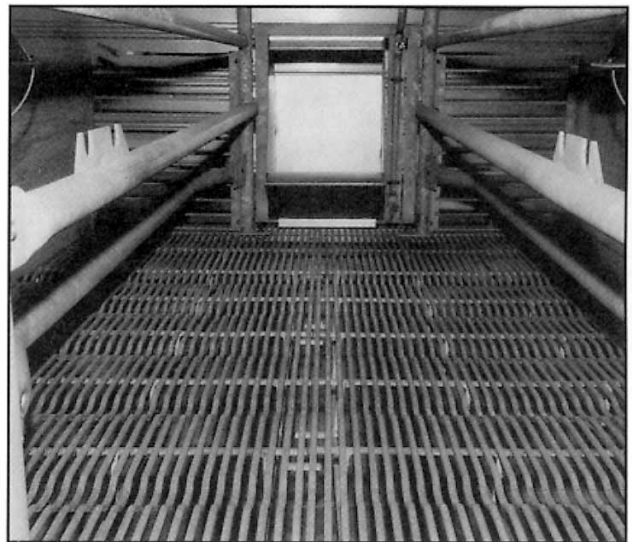

Figure 3. Farrowing crate with triangular steel bars deformed to facilitate traction.



Figure 4. Farrowing crate with flooring of plastisol covered expanded metal.

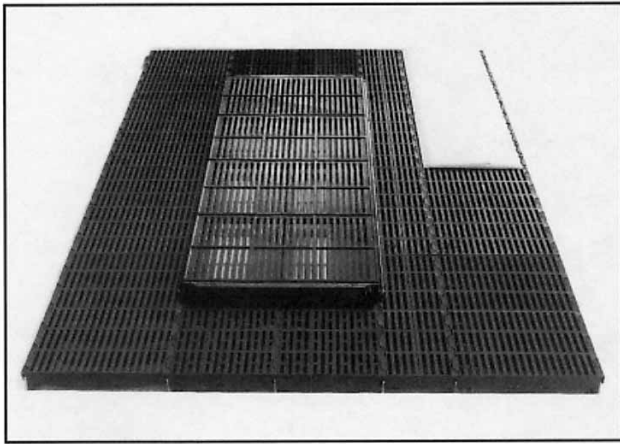

Figure 5. Modular constructed farrowing crate flooring with raised sow section and piglet heating pad (Courtesy Ikadan Systems).

Farrowing Arrangement

The normal arrangement for a farrowing unit with slotted floors was two rows of farrowing crates in a 22- to 24-ft. wide room (Figure 6). The crates normally face the center aisle for ease of feeding and sows seem to be more at ease when they can see other sows. Sows can be hand fed from a feed cart or from feeding stations located along the center aisle or they can be fed with a mechanized feeding system. The operator should observe each sow individually each day. If she does not eat or has not eaten her last feed, it is an indication that something is wrong.

With the tremendous interest in all-in, all-out management practices where all the sows in a room are bred so they farrow as a group within a week, separate rooms off a common hallway have become popular (Figure 7). Depending on the width of the building and the number of sows per room, the room may have only one row of crates with hallways front and rear. Each room might hold the

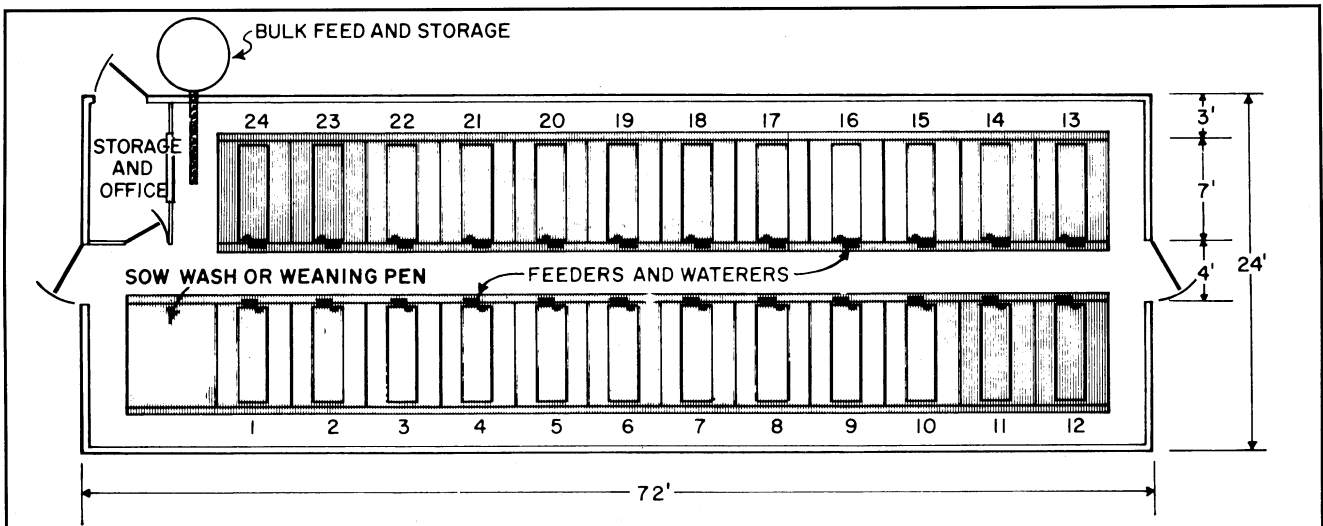

Figure 6. Floor plan of two-row, slotted floor farrowing house.

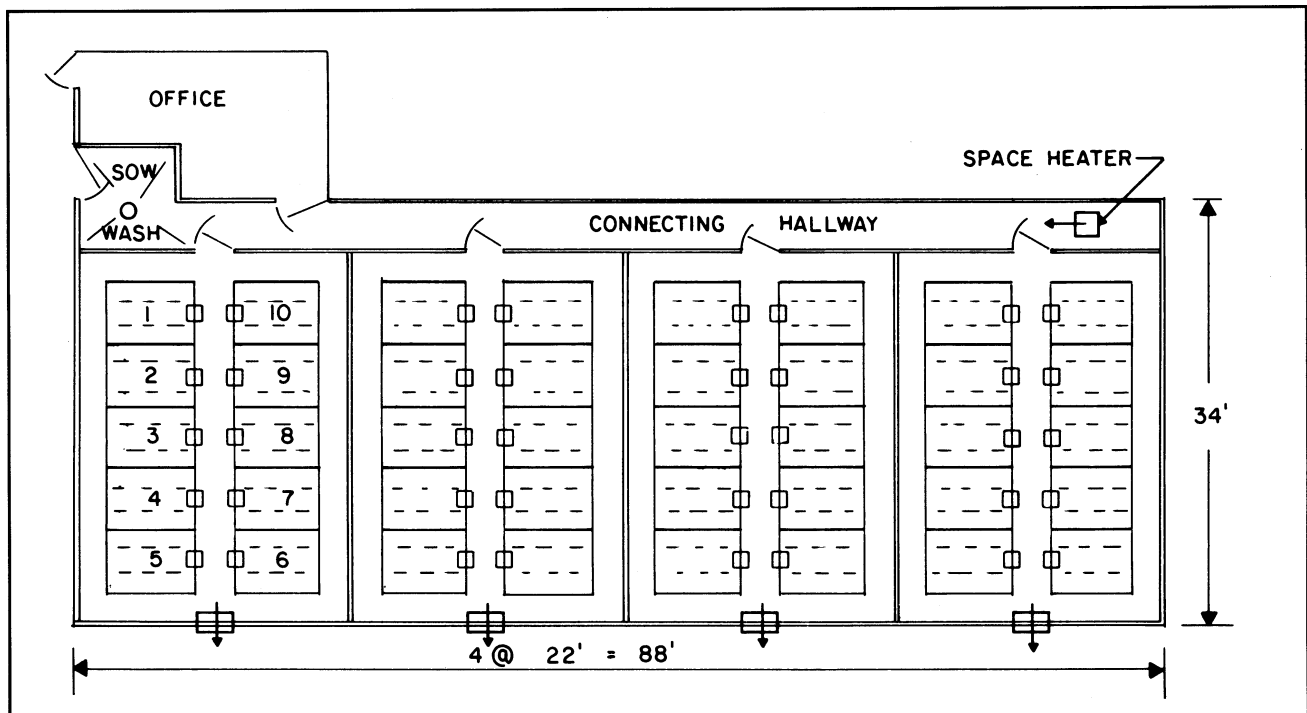

Figure 7. Floor plan of farrowing house with four separate rooms, each for ten sows.

number of crates for a week's farrowings. The rooms, manure systems, and ventilation systems should be constructed completely independently so an empty room can be cleaned and disinfected without affecting the other rooms. There should be no exchange of ventilation air from one room to another. Management is simplified because sows can be moved to and from crates easily and weaning and disinfecting can be done on a definite schedule. This type of arrangement is recommended for producers on a weekly farrowing schedule.

Manure Management

One important decision that must be made is how the manure is to be handled and stored. A large majority of producers use no bedding and handle all manure as a liquid and store the manure outside the building. With pen farrowing, producers may want to use bedding and handle the manure as a solid.

With the use of slotted floors, the manure can be stored under the slotted floors or, preferably, removed and stored in a separate manure storage unit or lagoon. The normal methods of removing the manure are by gravity drain to outside storage, by flushing or using pit recharge with recycled lagoon water, or by using a scraper. Gravity drain gutters are specially shaped gutters under slotted floors whereby liquid manure is allowed to accumulate for five to seven days and then drained to a storage unit. It is more common to use a shallow, flat bottom gutter instead of "y" or "v" shapes. A modification of the flat bottom is the "reversing hair-

pin" gutter (Figure 8). With a pit recharge system, the shallow gutter is drained once a week. Immediately after the gutter is drained to a lagoon, about one foot depth of the clearest lagoon water is pumped back into the gutter to help control odors and remove the solids when drained. For more information see PIH-95, "Gravity Drain Gutter Systems"; PIH- 63, "Recirculation Systems for Manure Removal"; and PIH-62, "Lagoon Management".

The size of the pit storage area determines how long manure is stored before emptying. Plan for about 4 gal (about 1/2 cu ft) of liquid manure per day for each sow and litter. Keep waterers in good repair. Excessive water leakage is expensive and can soon equal the amount of liquid manure production. A pit 2 ft to 3 ft deep is adequate for flushing or scraping. Below-floor manure storage is usually 4 ft to 8 ft deep.

The manure from solid floors should be cleaned daily from farrowing pens or crates, or the sows should be turned outside twice a day for feed and water. A mechanical gutter cleaner could be used to save labor. Bedding, whether straw, wood shavings or other material, must be used if the manure is to be handled as a solid. The bedding must be kept out of the liquid manure system because it can clog most pumping equipment.

Many of the older farrowing units with concrete slats and pit storage often require some renovation. Rough concrete may be causing abrasions on the little pig's knees and the producers would prefer to store the manure outside to improve conditions inside the building. A common remodeling method has been to pour a 12 in. curb around the slatted area and pour a 3 in. floor over

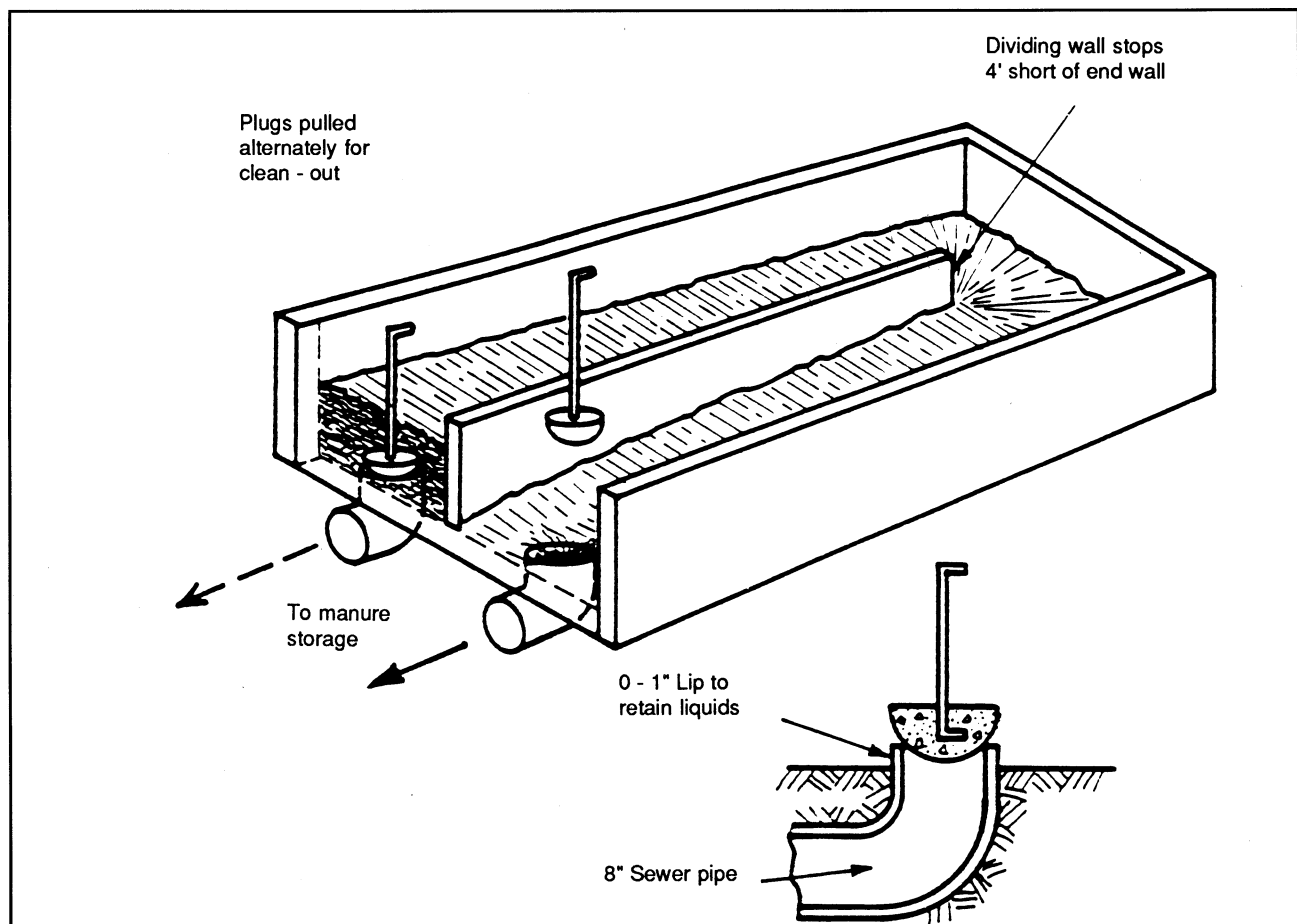

Figure 8. Perspective view of reversing hairpin gutter.

the slats (Figure 9). Pour the curb first, then the inside floor to get a good seal so the joint will not leak. The concrete slats are covered with plastic film or building paper before pouring a 3 in. concrete floor with a 4 in. drain hole into the storage. Elevated crates with new floors are installed above this new flat-bottomed gutter. The new plug is pulled periodically to drain the manure into the storage tank below. The reversing hairpin gutter described in PIH-95 could be used for the manure gutter. The manure gutter is washed out between farrowings.

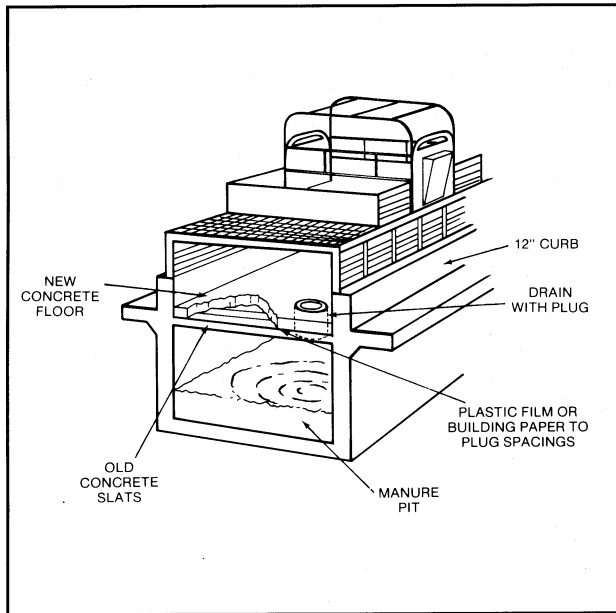

Figure 9. Conversion of farrowing crates with concrete slats over manure storage to sealed storage and raised crates.

Floor Level or Raised Crates

Raised crates can be used in newly constructed facilities and in remodeled buildings (Figure 10). When designed into new facilities, a minimum of 8 in. above the aisle floor is recommended. Figure 10(a) shows a raised crate over a shallow pit for flushing. Figures 10(b) and 10(c) show raised crates over gravity drain gutter arrangements. Raised crates require warmer temperatures and solid partitions to prevent chilling drafts on the pigs. A solid sleeping area and hovers also can provide more comfort for the pigs.

If solid floors are remodeled into raised crates, treated 2 x 10's on edge running perpendicular to the aisle can support the raised floor. On sloping floors, the 2 x 10's can be beveled to provide a level crate floor. Solid floors remodeled in this fashion require manure to be washed or scraped from between the 2 x 10's.

Although most sows can step up 8 in. to enter raised crates, this may not be desirable for sows heavy with pigs. In this case, a portable ramp should be used.

Construction Decisions

Materials

The materials used for construction should be selected for their appearance, durability, ease of cleaning, and cost.

Exterior sidewalls can be of any suitable building material—galvanized steel, painted steel, aluminum, exterior plywood, or conventional wood siding.

Roofing materials most frequently used are painted

or galvanized steel, painted or nonpainted aluminum, and asphalt or wood shingles.

Interior wall linings should be durable, easy to clean and able to withstand wear and corrosion. Many interior wall linings are easily damaged and hard to keep clean. Common linings are exterior plywood, fiberglass laminated to plywood or particleboard, tempered hardboard and metal covered with a protective coating.

Insulation in the form of batts and blankets is frequently used with stud frame construction because it is

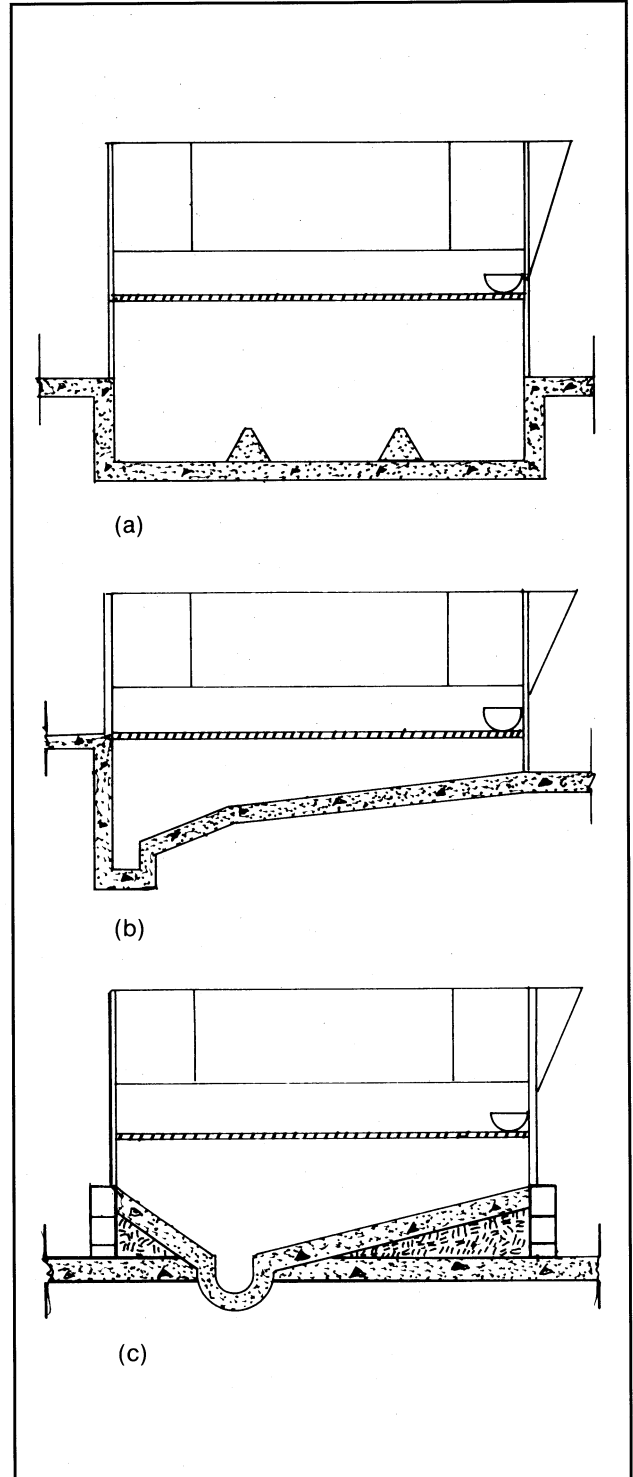

Figure 10. Raised farrowing crate with (a) shallow flushing gutter, (b) gravity drain gutter, and (c) gravity drain gutter remodeled building.

convenient to use and cost is low. It is common to blow in fiberglass or cellulose over flat ceilings as well as using batts or blankets. Polystyrene and urethane are also used but urethane will absorb moisture whereas closed-cell polystyrene (styrofoam) will not. Use polystyrene for perimeter insulation and to insulate under concrete floors, particularly in heated floors. Plan for a minimum R-value of 14 in the walls and 30 in the ceiling. More may be required in colder regions. The southern regions will benefit from insulation during extremely hot weather as well as during cold weather.

It is important to use fire-resistant insulation. Check the material to be used with your insurance company or high insurance rates may result. Protect sidewalls from pig access and mechanical damage. All insulation must be protected from rodents. For more detailed insulation information, see [PIH-65, "Insulation for Swine Housing"](#).

Vapor retarders (polyethylene film, 4 mil) are needed on the warm side of the wall, usually under the inside wall lining, to keep water vapor inside the building from entering the wall and condensing. They are also used under solid concrete floors to keep moisture from moving up from the ground and resulting in damp floors. More information on building materials is discussed in [PIH-32, "Building Materials and Equipment for Swine Facilities"](#).

Rodent and Bird Control

To control mice and rats, cover exposed perimeter insulation with a protective liner. Use tight construction and select materials to help prevent rodents from getting into or burrowing under the building. Maintain a clean building, free of sacks and old feed, and keep vegetation away from the building perimeter. Maintain a good rodent control program—do not wait until the building is already infested with mice and rats. For more information on rodent control, see [PIH-107, "Controlling Rats and Mice in Swine Facilities"](#).

Construct buildings so birds cannot roost near the insulation. Screen all vent openings using 1/2 in. x 1/2 in. hardware cloth for air intake vent openings and 3/4 in. x 3/4 in. hardware cloth for air outlet vent openings. Screened vent outlets are susceptible to freezing shut in cold climates, and ice may need to be removed from the screen regularly during cold weather. See [PIH-134, "Bird Management at Swine Facilities"](#).

Service Area

When planning a permanent farrowing facility, allow space for a service area (Figure 11) Provide an entrance into the office with a window for viewing the farrowing facilities and to allow visitors to see the farrowing quarters without having to enter the rooms. Include space for a sow wash area, equipment storage, record keeping, a refrigerator (for medication supplies), and possibly a feed cart.

Environmental Control

Ventilation removes moisture and odors in winter and heat in summer. Adequate air exchange capacities and proper distribution are important. Minimizing drafts is essential for small pigs.

Both negative (fans exhausting from the building) and

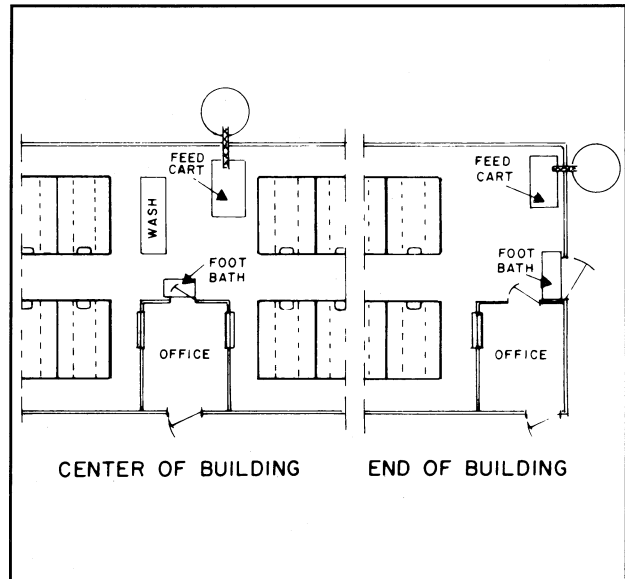

Figure 11. Locate the service area at one end or in the center of long farrowing houses.

positive (fans blowing into the building) pressure systems can meet the requirements if properly designed. The negative system is more common for winter ventilation. When using manure pits under slotted floors, exhausting a part or all of the ventilation air out through the pit will reduce odors inside the farrowing unit and help eliminate dangers from manure gases. For more detail on planning ventilation systems, see [PIH-60, "Mechanical Ventilation of Swine Buildings"](#).

Heated Units

Adequate heat is needed during cold weather in a farrowing house, particularly when slotted floors and no bedding are used. For buildings with slotted floors, use a space heater to maintain 72°F in the room, and supplemental heaters as needed to provide extra heat for the small pigs. Supplemental heaters include heat lamps, gas or electric radiant heaters, and hot water or electric floor heat and heating pads. Use part solid floors under radiant heaters, when possible, as they heat the objects they strike, pass through slotted floors and heat the manure or flush water below. In some states, heating fuel costs can be lowered by the use of solar heat. Air-to-air exchangers and earth-tube heat exchangers also will help reduce fuel costs.

Preheating the fresh air before it enters the farrowing room will reduce chilling next to the air inlets during extremely cold weather. This can be accomplished in the multiroom farrowing unit (Figure 10) by providing a heater in the connecting hallway and drawing the incoming air from the hallway. For more information on supplemental heat, see [PIH-57, "Supplemental Heat for Swine"](#).

Summer Cooling

Proper summer cooling requires considerably more air movement than for winter. During extremely hot weather, the ventilation system could be supplemented with a fan blowing over the sows. Evaporative cooling

works well, even in relatively humid climates, such as the Southeast. Drip irrigation nozzles used to drip water at a rate of about 0.8 gal/hr on the sow's shoulder also provide cooling. For more detailed information on cooling, see PIH-87, "Cooling Swine".

Planning Information

Table 1 lists planning information for quick reference.

Table 1. Information for Planning.

Suggested temperatures (winter)	Heating and cooling	Ventilation
Inside air Solid floors--60-65° F Slotted floors--70-75° F Floor temperature, pigs--90-95° F at farrowing	Supplemental heater--3,000-4,000 BTU/hr/sow and litter Heat lamp--250 watts/litter Floor heat Electric--30-40 watts/sq ft Hot water--50 BTU/hr/ft of pipe Gas infrared--2,500-4,000 BTU/hr/litter Zone cooling--50-75 cfm/sow Zone air conditioning--0.15 tons/crate	Cold weather--20 cfm minimum/sow and litter Mild weather--80-100 cfm/sow and litter Hot weather--500-1000 cfm/sow and litter
Slotted floors	Manure production	
Slot width--3/8 in. except behind sow (1 in. in 2 ft x 2 ft area) Slat width--4-6 in. (metal or plastic may be narrower)	Sow and litter--4 gal/day (.54 cu ft/day)	

Reference to products in this publication is not intended to be an endorsement to the exclusion of others which may be similar. Persons using such products assume responsibility for their use in accordance with current directions of the manufacturer.

The information represented herein is believed to be accurate but is in no way guaranteed. The authors, reviewers, and publishers assume no liability in connection with any use for the products discussed and make no warranty, expressed or implied, in that respect, nor can it be assumed that all safety measures are indicated herein or that additional measures may be required. The user, therefore, must assume full responsibility, both as to persons and as to property, for the use of these materials including any which might be covered by patent.

This material may be available in alternative formats.